

BLACK & DECKER®

www.blackanddecker.co.uk

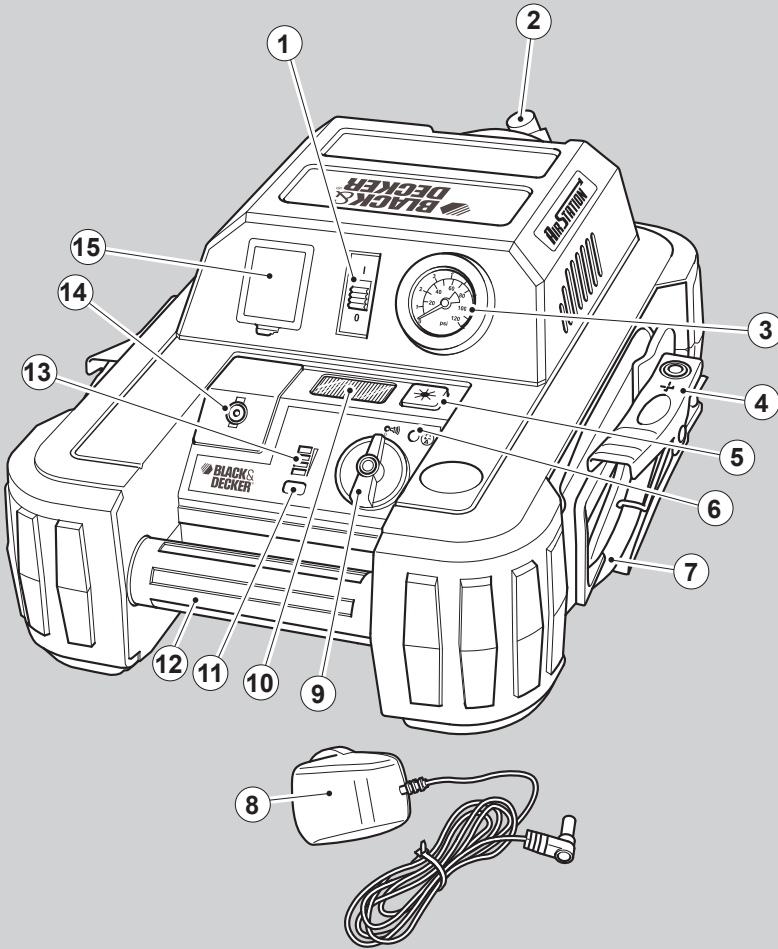

UK

Ireland

Australia

New Zealand

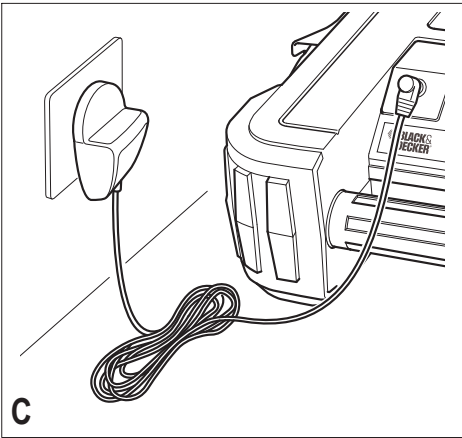
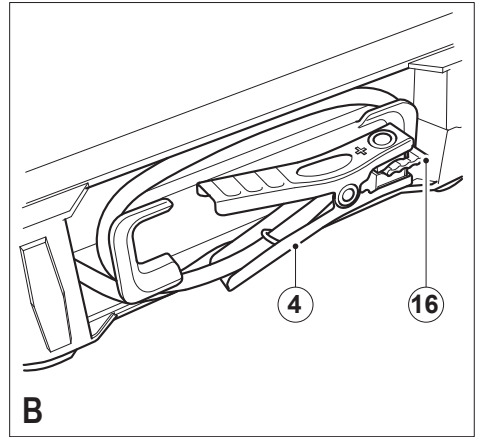
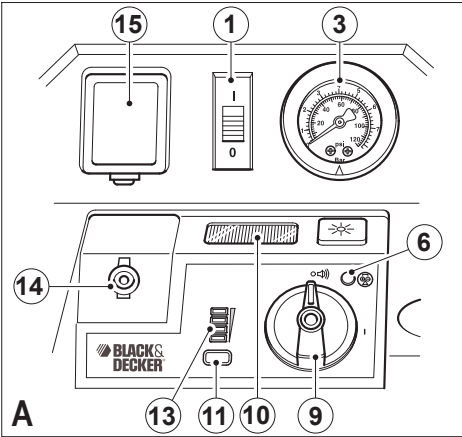

Intended use

Your Black & Decker jump starter is designed to provide additional power to lead-acid batteries when starting car engines, the cordless inflator is designed inflate car tyres and sports equipment. This product is intended for household, consumer use only.

Safety instructions

Warning! When using battery-powered appliances, basic safety precautions, including the following, should always be followed to reduce the risk of fire, leaking batteries, personal injury and material damage.

- ◆ Read all of this manual carefully before using the appliance.
- ◆ The intended use is described in this manual. The use of any accessory or attachment or the performance of any operation with this appliance other than those recommended in this instruction manual may present a risk of personal injury.
- ◆ Retain this manual for future reference.

Using your appliance

- ◆ Always take care when using the appliance.
- ◆ This appliance is not intended for use by young or infirm persons without supervision.
- ◆ The appliance is not to be used as a toy.
- ◆ Use in a dry location only. Do not allow the appliance to become wet.
- ◆ Do not immerse the appliance in water.
- ◆ Do not open body casing. There are no user-serviceable parts inside.
- ◆ Do not operate the appliance in explosive atmospheres, such as in the presence of flammable liquids, gases or dust.
- ◆ Only use the appliance in a well ventilated area.
- ◆ To reduce the risk of damage to plugs and cords never pull the cable to remove the plug from a socket.

Safety of others

- ◆ This appliance is not intended for use by persons (including children) with reduced physical, sensory or mental capabilities, or lack of experience and knowledge, unless they have been given supervision or instruction concerning use of the appliance by a person responsible for the their safety.
- ◆ Children should be supervised to ensure that they do not play with the appliance.

After use

- ◆ When not in use, the appliance should be stored in a dry, well ventilated place out of the reach of children.
- ◆ Children should not have access to stored appliances.

- ◆ When the appliance is stored or transported in a vehicle it should be placed in the boot or restrained to prevent movement following sudden changes in speed or direction.
- ◆ The appliance should be protected from direct sunlight, heat and moisture.

Inspection and repairs

- ◆ Before use, check the appliance for damaged or defective parts. Check for breakage of parts, damage to switches and any other conditions that may affect its operation.
- ◆ Do not use the appliance if any part is damaged or defective.
- ◆ Have any damaged or defective parts repaired or replaced by an authorised repair agent.
- ◆ Never attempt to remove or replace any parts other than those specified in this manual.

Specific safety instructions for jump starters

The following symbols are marked on the appliance:



Read all of this instruction manual carefully.



Do not use the appliance in wet conditions or expose it to rain.



Explosive gases. Prevent flames and sparks and provide adequate ventilation during charging.



Reverse polarity indicator.

- ◆ Vehicles may have electrical and electronic systems (e.g. engine management system, mobile phone) that may be damaged if subjected to high starting voltages and voltage peaks. Before connecting the appliance to the vehicle read the vehicle's owner's manual to confirm that external-starting assistance is allowed.
- ◆ Follow these instructions and those published by the battery manufacturer, vehicle manufacturer and manufacturer of any equipment you intend to use with this unit. Review warning labels on these products and on the vehicle.
- ◆ This appliance is not designed to be used as a replacement for a vehicular battery. Do not attempt to operate a vehicle that does not have a battery installed.
- ◆ The appliance must only be connected to a 12V lead-acid battery.

Warning! Do not use the appliance for charging dry-cell batteries that are commonly used with home appliances. These batteries may burst and cause injury to persons or damage to property.

- ◆ Check the polarity of the vehicle battery terminals before connecting the appliance. Always disconnect the negative (black) jumper cable first: followed by the positive (red) jumper cable.
- ◆ The ON/OFF switch should be in the OFF position before connection to a power source or load, when the unit is charging and when not in use.

Warning! Never allow the red and black clamps to touch each other or another common metal conductor. This could cause damage to the appliance and/or create a sparking/explosion hazard. Always store the battery clamps in the built-in holsters when not in use.

- ◆ When using this unit in proximity to the vehicle's battery and engine, stand the unit on a flat, stable surface, and be sure to keep all clamps, cords, clothing and body parts away from moving parts of the vehicle.
- ◆ This appliance contains a sealed lead-acid battery. It is recommended that the appliance is laid flat during storage, use, and recharging.

Warning! Explosive gas may be vented from the lead acid batteries when charging and under extreme conditions battery leakage may occur. Ensure the area is well ventilated when conducting jump starting and charging procedures.

- ◆ To reduce the risk of electric shock, disconnect the appliance from any power source before attempting maintenance or cleaning. Turning off controls without disconnecting the appliance will not reduce this risk.
- ◆ Make sure the appliance is disconnected from all charging power sources before beginning the jump start procedure.

Additional safety warnings for inflators

- ◆ For home and car use only. Inflate car and bike tyres, balls, rafts, swimming pool floats, air mattresses, and more in and around the home.
- ◆ The compressed air from your inflator is not safe for breathing. Never inhale air from your inflator or from a breathing device connected to the inflator.
- ◆ Inflate items only to their manufacturer's recommendations. Exceeding the pressure rating could cause them to explode resulting in personal injury.
- ◆ Do not leave inflator running unattended. It could burst tyres or other items.
- ◆ Since the vibration produced by the inflator may cause it to "walk", do not operate on a high shelf or other surface. Operate at ground or bench level.

- ◆ Do not modify or attempt to repair. Never drill into, weld, or make any modifications to the inflator or its attachments.
- ◆ Do not operate inflator when the car engine is running.
- ◆ Operate only with the accessories included or those rated for 8.28 bar/120 p.s.i. or higher. The use of any accessory not recommended for use with this tool could be hazardous.
- ◆ Do not play with the tool. High pressure air is dangerous. Don't direct air-flow at yourself or others.
- ◆ The inflator can become hot during use. Allow inflator to cool for 30 minutes before storing away.
- ◆ Never carry the inflator by the hose.
- ◆ This tool is not intended for use by persons (including children) with reduced physical, sensory or mental capabilities, or lack of experience and knowledge, unless they have been given supervision or instruction concerning use of the appliance by a person responsible for their safety. Children should be supervised to ensure that they do not play with the appliance.

Additional safety instructions for batteries and chargers

Batteries

- ◆ Never attempt to open for any reason.
- ◆ Do not expose the battery to water.
- ◆ Do not expose the battery to heat.
- ◆ Do not store in locations where the temperature may exceed 40°C.
- ◆ Charge only at ambient temperatures between 10°C and 40°C.
- ◆ Charge only using the charger provided with the appliance/tool.
- ◆ When disposing of batteries, follow the instructions given in the section "Protecting the environment".
- ◆ Do not damage/deform the battery pack either by puncture or impact, as this may create a risk of injury and fire.
- ◆ Do not charge damaged batteries.
- ◆ Under extreme conditions, battery leakage may occur. When you notice liquid on the batteries
- ◆ Carefully wipe the liquid off using a cloth. Avoid skin contact.
- ◆ In case of skin or eye contact, follow the instructions below.

Warning! The battery fluid may cause personal injury or damage to property. In case of skin contact, immediately rinse with water. If redness, pain or irritation occurs seek medical attention. In case of eye contact, rinse immediately with clean water and seek medical attention.

Chargers

Your charger has been designed for a specific voltage. Always check that the mains voltage corresponds to the voltage on the rating plate.

Warning! Never attempt to replace the charger unit with a regular mains plug.

- ◆ Use your Black & Decker charger only to charge the battery in the appliance/tool with which it was supplied. Other batteries could burst, causing personal injury and damage.
- ◆ Never attempt to charge non-rechargeable batteries.
- ◆ If the supply cord is damaged, it must be replaced by the manufacturer or an authorised Black & Decker Service Centre in order to avoid a hazard.
- ◆ Do not expose the charger to water.
- ◆ Do not open the charger.
- ◆ Do not probe the charger.
- ◆ The appliance/tool/battery must be placed in a well ventilated area when charging.



F Fail-safe isolating transformer. The mains supply is electrically separated from the transformer output.



130°C The charger automatically shuts off if the ambient temperature becomes too high. As a consequence the charger will be inoperable. The charging base must be disconnected from the mains supply and taken to an authorised service centre for repair.



Read all of this instruction manual carefully.



This appliance is intended for indoor use only

Electrical safety



Your charger is double insulated; therefore no earth wire is required. Always check that the mains voltage corresponds to the voltage on the rating plate.

- ◆ If the supply cord is damaged, it must be replaced by the manufacturer or an authorised Black & Decker Service Centre in order to avoid a hazard.

Warning! Never attempt to replace the charger unit with a regular mains plug.

Features

This appliance includes some or all of the following features:

1. Inflator on/off switch
2. Air hose with universal valve adaptor
3. Pressure gauge
4. Heavy-duty copper clamps
5. LED area light on/off switch
6. Reverse polarity indicator
7. Jumper cables
8. Mains charging adaptor
9. ON/OFF switch
10. LED area light
11. Battery status pushbutton
12. Carry handle
13. Battery status LEDs
14. 12 Vdc charging socket
15. Accessory storage
16. Clamp holders

Use

Charging the unit (fig. A)

This unit is shipped in a partially charged state.

- ◆ Charge the unit before first use using the mains charging adaptor (8) for 48 hours.

Lead-acid batteries require routine maintenance to ensure a full charge and a long battery life. All batteries lose energy from self-discharge over time and more rapidly at higher temperatures. When the unit is not in use, Black & Decker recommend that the battery is charged at least every 60 days.

- ◆ Check the battery charge level by pressing the battery status pushbutton (11). The LED charge status display (13) will indicate the level of battery charge. When only one red LED lights, charge the unit.

Note: Charging the battery after each use will prolong the battery life; frequent heavy discharges between charges and/or overcharging will reduce battery life.

The battery can be charged using the mains charging adaptor (8).

Charging the unit with the mains charger (fig. C)

Make sure that the ON/OFF switch (9) and the LED area light (10) are turned off while the unit is being charged.

- ◆ Insert the jack plug of the charging adaptor (8) into the charging socket (14).
- ◆ Insert the charging adaptor (8) into a mains power socket.

As charging progresses, the red LEDs will light one by one.

- ◆ Charge the unit until the green FULL LED lights/flashes.
- ◆ Continue to charge for one to two more hours.

Note: The mains charging should not be connected for more than 60 hours.

- ◆ When charging is complete remove the charging adaptor (8) from the mains power socket.
- ◆ Remove the charging jack plug from the charging socket (14) and store in a safe place.

Using the unit as a jump-starter (fig. A & B)

Warning! Make sure that the vehicle is in neutral with the parking brake applied.

Note: If your connections are incorrectly made, the unit will beep continuously and the red reverse polarity indicator (6) will light, even if the ON/OFF switch (9) is in the OFF position. Rectify the connections immediately.

Warning! Make sure that the cables are not in the path of moving belts or the fan.

1. Turn off the vehicles ignition and all accessories before making any connections.
2. Make sure that the units ON/OFF switch (9) is turned OFF.
3. The following procedure is for a negative earth system ie the negative battery terminal is connected to the chassis.
4. Connect the positive (+) red clamp to the vehicle's positive battery terminal.
5. Connect the negative (-) black clamp to chassis or a solid, non-moving, metal vehicle component or chassis part. Never clamp directly to negative battery terminal or moving part. Refer to the automobile owner's manual.
6. Turn the unit's ON/OFF switch (9) to the ON position.
7. Start the vehicle and crank the engine in 3 to 6 second bursts.
 - ◆ If the engine doesn't start within 6 seconds let the units internal battery cool for 3 minutes before making another attempt.
8. When the vehicle starts, turn the unit's OFF/ON switch (9) to the OFF position.
9. Leave the vehicle's engine running.
10. Disconnect the (-) black clamp connected to the engine or chassis first, followed by the (+) red clamp that is connected to the battery positive (+) terminal.
11. Carefully press the negative (black) jumper cable wire into the storage channel starting at the end furthest from the clamp.

12. Clamp the negative (black) clamp onto the clamp holder (16).
13. Carefully press the positive (red) jumper cable wire into the storage channel starting at the end furthest from the clamp.
14. Clamp the positive (red) clamp onto the clamp holder (16).
15. Charge the unit as soon as possible.

Note: After each use, clean the battery clamps (4) and be sure to remove any battery fluid that will cause corrosion of the clamps (4). Keep the battery charger cords loosely coiled during storage to prevent damage to the cords.

Using the LED area light (fig. A)

The LED area light (10) will operate up to 50 hours on a full charge. The LED area light's operating life is 100,000 hours.

- ◆ Press the LED area light on/off switch (5) on the top panel of the unit to turn the LED area light (10) on.
- ◆ Press the LED area light on/off switch (5) again to turn the LED area light (10) off.

Make sure that the LED area light is turned off while the unit is being charged or stored.

Using the inflator (fig. A)

Warning! When using the inflator:

- ◆ Do not use the inflator when the charger is connected to the mains.
- ◆ Do not direct the nozzle at animals or bystanders.
- ◆ Never leave the compressor unattended when running.
- ◆ Only use the adaptors supplied.
- ◆ Should the unit run over an extended period of time it may overheat and cause the thermal trip to activate. When this occurs switch the compressor off and allow to cool for 30 minutes.
- ◆ Keep the compressor stored out of reach of small children.
- ◆ The gauge is intended as a guide only. Tyre pressures should be regularly checked with a certified gauge.
- ◆ Do not over inflate any object as this may cause a risk of injury.

This inflator can be used to inflate car tyres and sports equipment.

- ◆ Remove the inflator hose from the storage compartment.
- ◆ If an adaptor is required, choose the correct adaptor for the product you are inflating and fit it into the nozzle (2).
- ◆ Fit the nozzle (2) of the inflator or the adaptor, if fitted, to the valve of the item to be inflated. Make sure that the nozzle (2) is locked in place.
- ◆ Move the inflator on/off switch (1) to the on position (I).

- ◆ Monitor the pressure gauge (3) until the required pressure is reached.
- ◆ Move the inflator on/off switch (1) to the off position (0).
- ◆ Remove the adaptor, if fitted, or the nozzle (2) from the inflated item.
- ◆ Remove the adaptor, if fitted, and store it in the inflator nozzle storage compartment (15).

Maintenance

Your Black & Decker corded/cordless appliance/tool has been designed to operate over a long period of time with a minimum of maintenance. Continuous satisfactory operation depends upon proper tool care and regular cleaning.

Warning! Before performing any maintenance on corded/cordless power tools:

- ◆ Switch off and unplug the appliance/tool.
- ◆ Or switch off and remove the battery from the appliance/tool if the appliance/tool has a separate battery pack.
- ◆ Or run the battery down completely if it is integral and then switch off.
- ◆ Unplug the charger before cleaning it. Your charger does not require any maintenance apart from regular cleaning.

Regularly clean the ventilation slots in you appliance/tool/charger using a soft brush or dry cloth.

Regularly clean the motor housing using a damp cloth. Do not use any abrasive or solvent-based cleaner.

Regularly open the chuck and tap it to remove any dust from the interior (when fitted).

Protecting the environment



Separate collection. This product must not be disposed of with normal household waste.

Should you find one day that your Black & Decker product needs replacement, or if it is of no further use to you, do not dispose of it with household waste. Make this product available for separate collection.



Separate collection of used products and packaging allows materials to be recycled and used again. Re-use of recycled materials helps prevent environmental pollution and reduces the demand for raw materials.

Local regulations may provide for separate collection of electrical products from the household, at municipal waste sites or by the retailer when you purchase a new product.

Black & Decker provides a facility for the collection and recycling of Black & Decker products once they have reached the end of their working life. To take advantage of this service please return your product to any authorised repair agent who will collect them on our behalf.

You can check the location of your nearest authorised repair agent by contacting your local Black & Decker office at the address indicated in this manual. Alternatively, a list of authorised Black & Decker repair agents and full details of our after-sales service and contacts are available on the Internet at: www.2helpU.com.



At the end of their useful life, discard batteries with due care for our environment:

- ◆ Do not short-circuit the battery terminals.
- ◆ Do not dispose of the battery(s) in a fire as this may result in a risk of personal injury or an Explosion.
- ◆ Run the battery down completely, then remove it from the tool.
- ◆ Batteries are recyclable. Place the battery(s) in a suitable packaging to ensure that the terminals cannot be short-circuited. Take them to any authorised repair agent or a local recycling station.

Technical data

BDJS450I	
Battery	Type 12 V 17 Ah sealed lead acid
Output (instant)	A 450
Output (constant for 5 seconds)	A 300
Weight	kg 7
Inflator	
Pressure (max)	bar/p.s.i 8.28/120
Battery charger	
Input	Vac 230
Approx. charging time	h 48
Weight	kg 0.48

EC declaration of conformity

BDJS450I H1

Black & Decker declares that these products conform to:
Standards & Legislation.
EN60335, 2006/95/EC

The undersigned is responsible for compilation of the technical file and makes this declaration on behalf of
Black & Decker.



Kevin Hewitt
Director of Consumer Engineering
Spennymoor, County Durham, DL16 6JG,
United Kingdom
07-07-2009

- ◆ The product has sustained damage through foreign objects, substances or accidents.
- ◆ Repairs have been attempted by persons other than authorised repair agents or Black & Decker service staff.

To claim on the guarantee, you will need to submit proof of purchase to the seller or an authorised repair agent. You can check the location of your nearest authorised repair agent by contacting your local Black & Decker office at the address indicated in this manual. Alternatively, a list of authorised Black & Decker repair agents and full details of our after-sales service and contacts are available on the Internet at: **www.2helpU.com**

Please visit our website **www.blackanddecker.co.uk** to register your new Black & Decker product and to be kept up to date on new products and special offers. Further information on the Black & Decker brand and our range of products is available at **www.blackanddecker.co.uk**.

Guarantee

Black & Decker is confident of the quality of its products and offers an outstanding guarantee. This guarantee statement is in addition to and in no way prejudices your statutory rights. The guarantee is valid within the territories of the Member States of the European Union and the European Free Trade Area.

If a Black & Decker product becomes defective due to faulty materials, workmanship or lack of conformity, within 24 months from the date of purchase, Black & Decker guarantees to replace defective parts, repair products subjected to fair wear and tear or replace such products to make sure of the minimum inconvenience to the customer unless:

- ◆ The product has been used for trade, professional or hire purposes.
- ◆ The product has been subjected to misuse or neglect.

Partial support - Only parts shown available
Nur die aufgefuehrten teile sind lieferbar
Reparation partielle - Seules les pieces indiquees sont disponibles
Supporto parziale - Sono disponibili soltanto le parti evidenziate
Solo estan disponibles las peizas listadas
So se encontram disponibles as pecas listadas
Gedeeltelijke ondersteuning - alleen de getoonde onderdelen
zijn beschikbaar

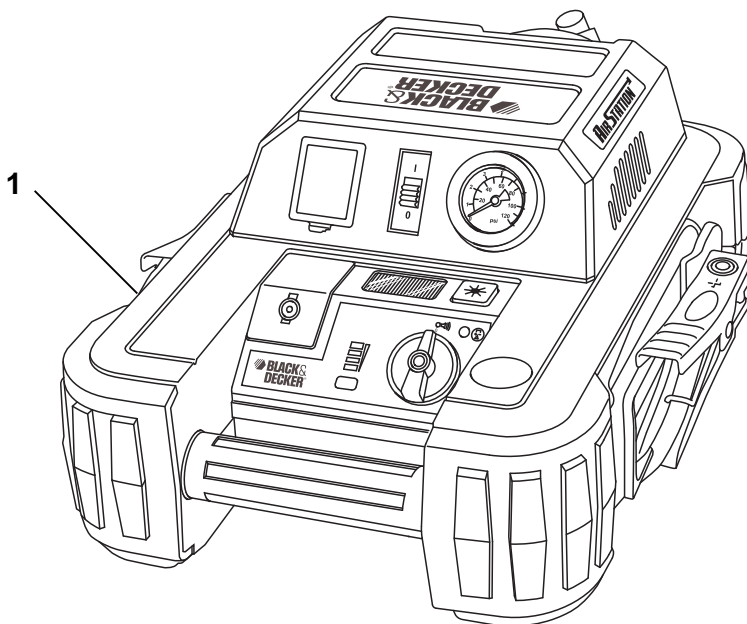

3

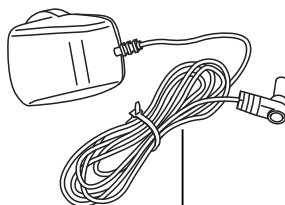
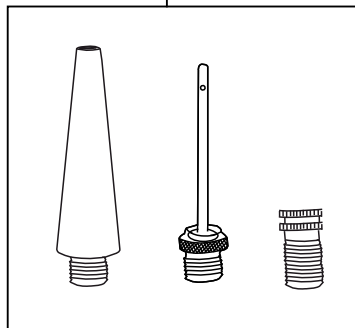

2

Australia

Black & Decker (Australia) Pty. Ltd.
20 Fletcher Road, Mooroolbark,
Victoria, 3138

Tel. 03-8720 5100
Fax 03-9727 5940

New Zealand

Black & Decker
5 Te Apunga Place
Mt Wellington
Auckland 1060

Tel. +64 9 259 1133
Fax +64 9 259 1122

United Kingdom

Black & Decker
210 Bath Road
Slough, Berkshire SL1 3YD

Tel. 01753 511234
Fax 01753 551155
Helpline 01753 574277